

MULTICELL™ Heaters

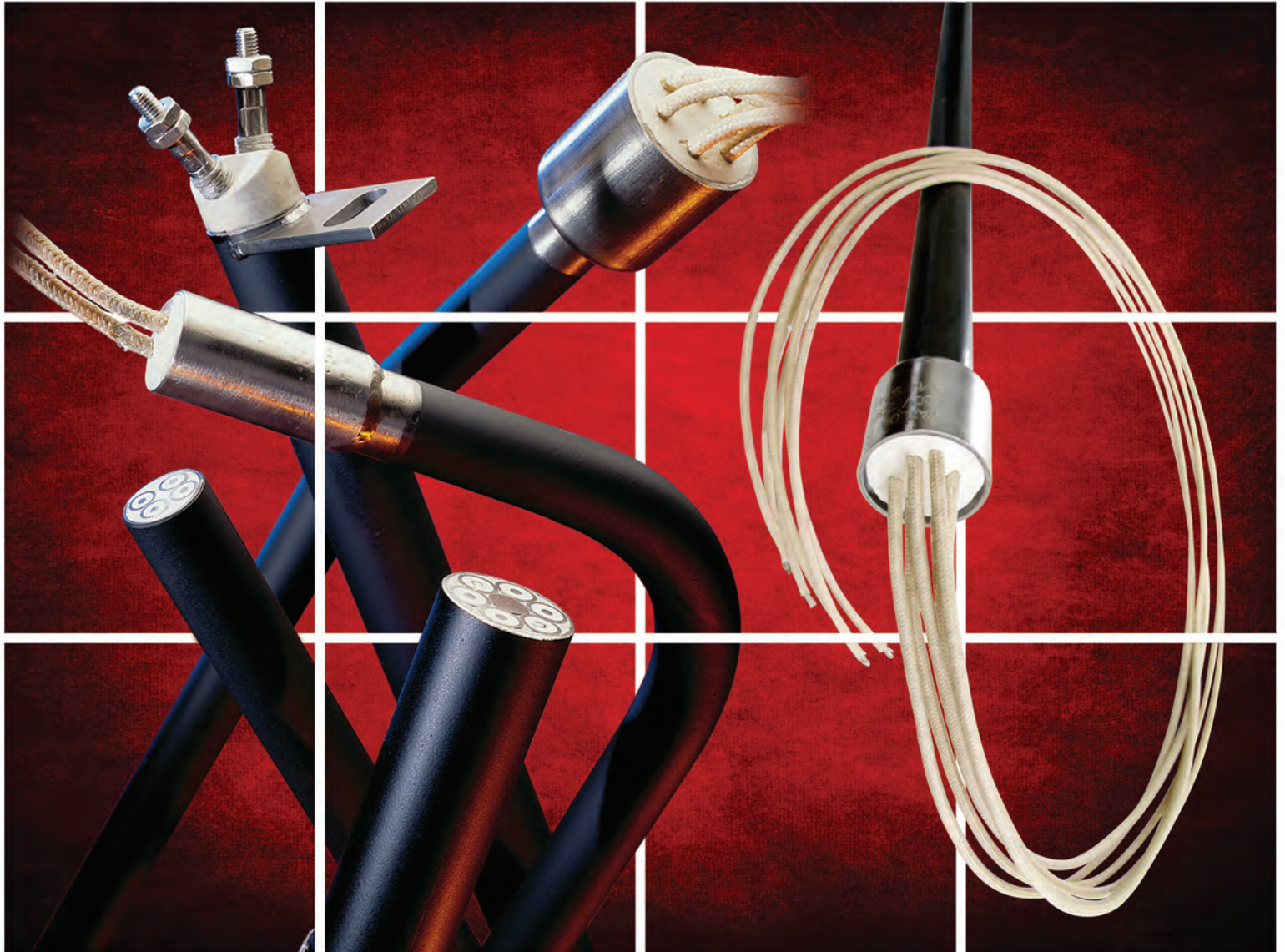

heaters | sensors | controllers

MULTICELL™ HEATERS

UNIQUE
ADVANTAGES
FOR
DEMANDING
OPERATIONS



MULTICELL HEATERS: THE HIGH TEMPERATURE CHOICE

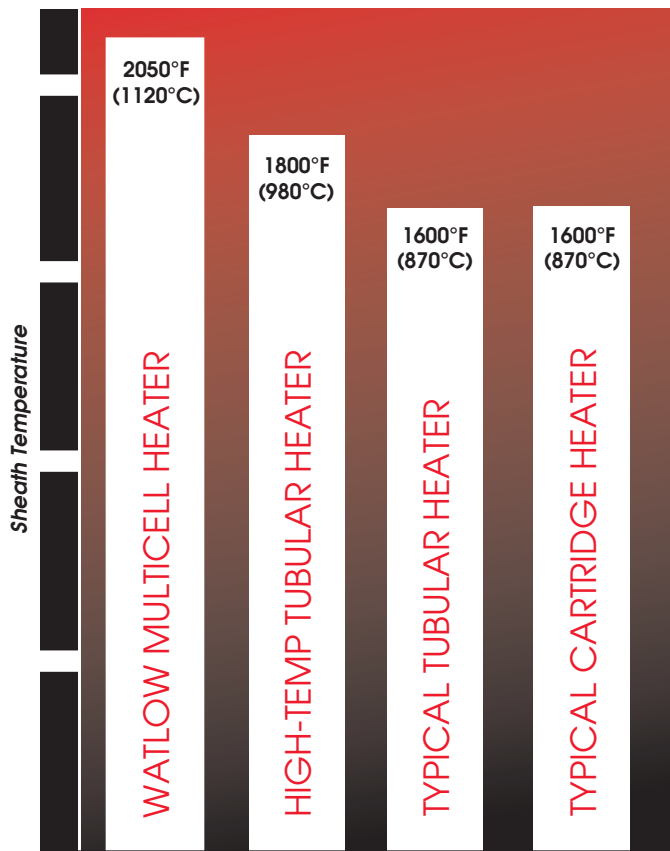

When your processes demand high temperatures and reliable heat, Watlow® MULTICELL™ heaters deliver the performance you need.

Engineered to handle applications that demand high temperatures, MULTICELL heaters from Watlow have a rugged construction that permits the heaters to survive in conditions that would normally be lethal to other heater types. These MULTICELL heaters have been engineered to achieve process temperatures up to 2050°F (1120°C).

Watlow's radiant MULTICELL heater design can include up to six individual metal-sheathed cells compressed into a larger outer sheath. This double-sheath feature allows efficient heat dissipation, maximum protection against coil oxidation and long life under the most demanding conditions.

This cross sectional drawing of a MULTICELL heater shows six individual metal-sheathed cells. MULTICELL heaters with up to six individual cells are available.



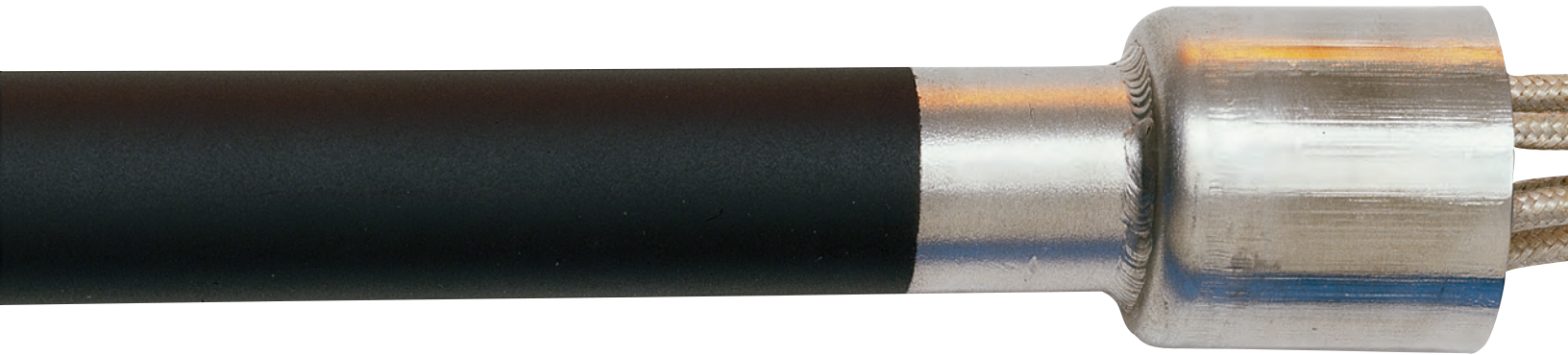

UNIQUE MULTICELL FEATURES FOR DEMANDING APPLICATIONS

- Multiple, independently controllable zones allow **precise process temperature uniformity** not possible with any other single-sheathed heater.
- Allows for replaceable temperature sensors in internal thermowells for **ease of maintenance** and minimal downtime.
- The heater's radiant design allows for loose insertion into bored holes and pipes. Since it will not bind or seize in the hole, the heater is **easily removed and replaced with minimal downtime**.
- The oxidized sheath provides high emissivity which **improves** as oxidation increases.
- Individual, metal-sheathed coils are compressed into a larger, high temperature alloy outer sheath for **maximum protection against coil oxidation**.
- Satisfies **long length heater** needs providing reduced wiring.

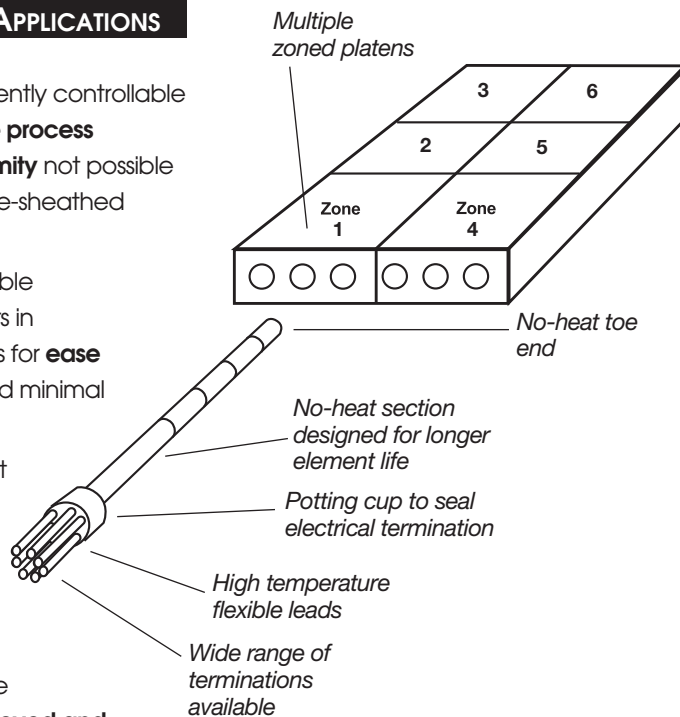

- Quick disconnect plug and jack permit **fast replacement** of individual elements while the equipment stays at operating temperature.
- **Special bending capabilities** solve unusual machinery needs with greater versatility and keep leads away from heated zones.
- Extreme **process temperatures** engineered to 2050°F (1120°C).

MULTICELL APPLICATIONS

Watlow's MULTICELL heaters meet the challenges of the most demanding processes.

- Aluminum processing
- Environmental
- Superplastic forming (SPF)
- Diffusion bonding (SPF-DB)
- Glass forming ovens
- HIP
- Hazardous waste treatment systems
- Heat treating processes
- Hot forging dies
- Hot gas generation
- Hot isothermal forming
- Molten metal heating
- Soil remediation
- Polysilicon ingots

Whether your need is for multiple or single zone control, Watlow's radiant MULTICELL heaters are an excellent heat solution option. Contact your local Watlow representative to find your heating solution today.

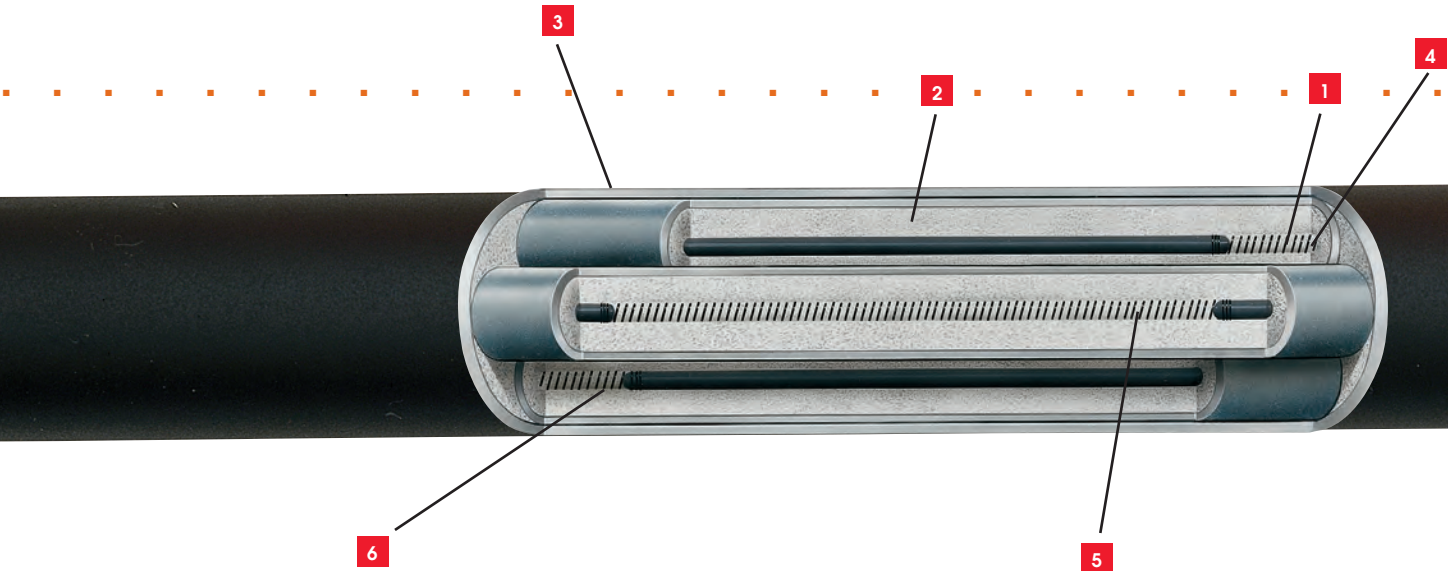

SINGLE ZONE MULTICELL ELEMENTS*

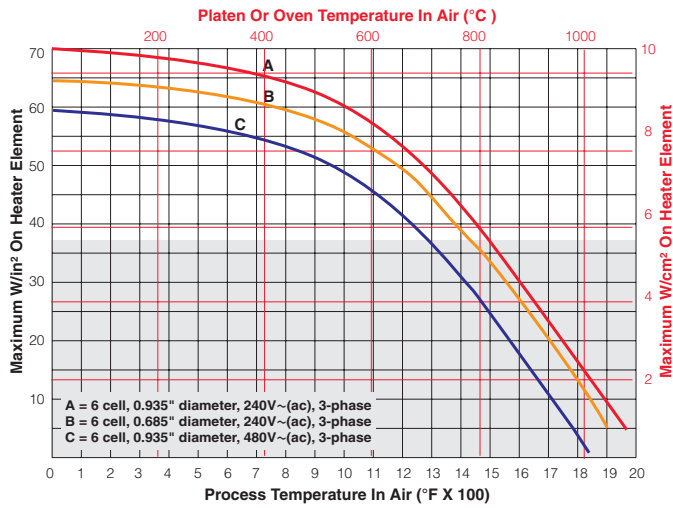

Note: Shaded area is standard. Non-shaded area, consult factory.

THREE ZONE MULTICELL ELEMENTS*

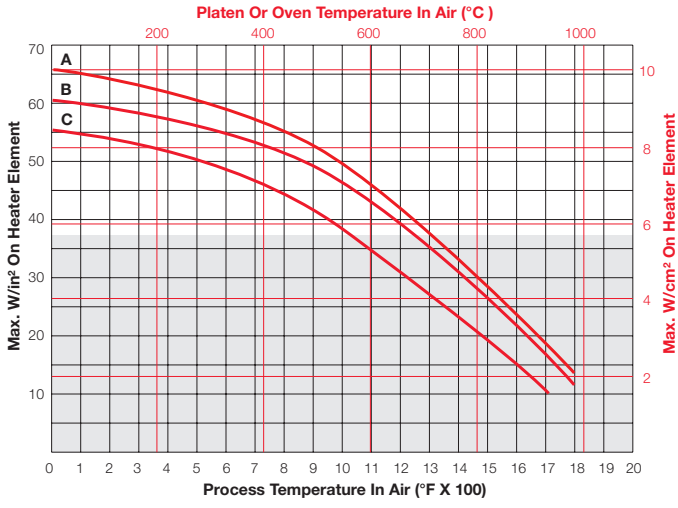

Note: Shaded area is standard. Non-shaded area, consult factory.
 *Other designs and voltages with higher temperature capabilities are available. Consult factory.

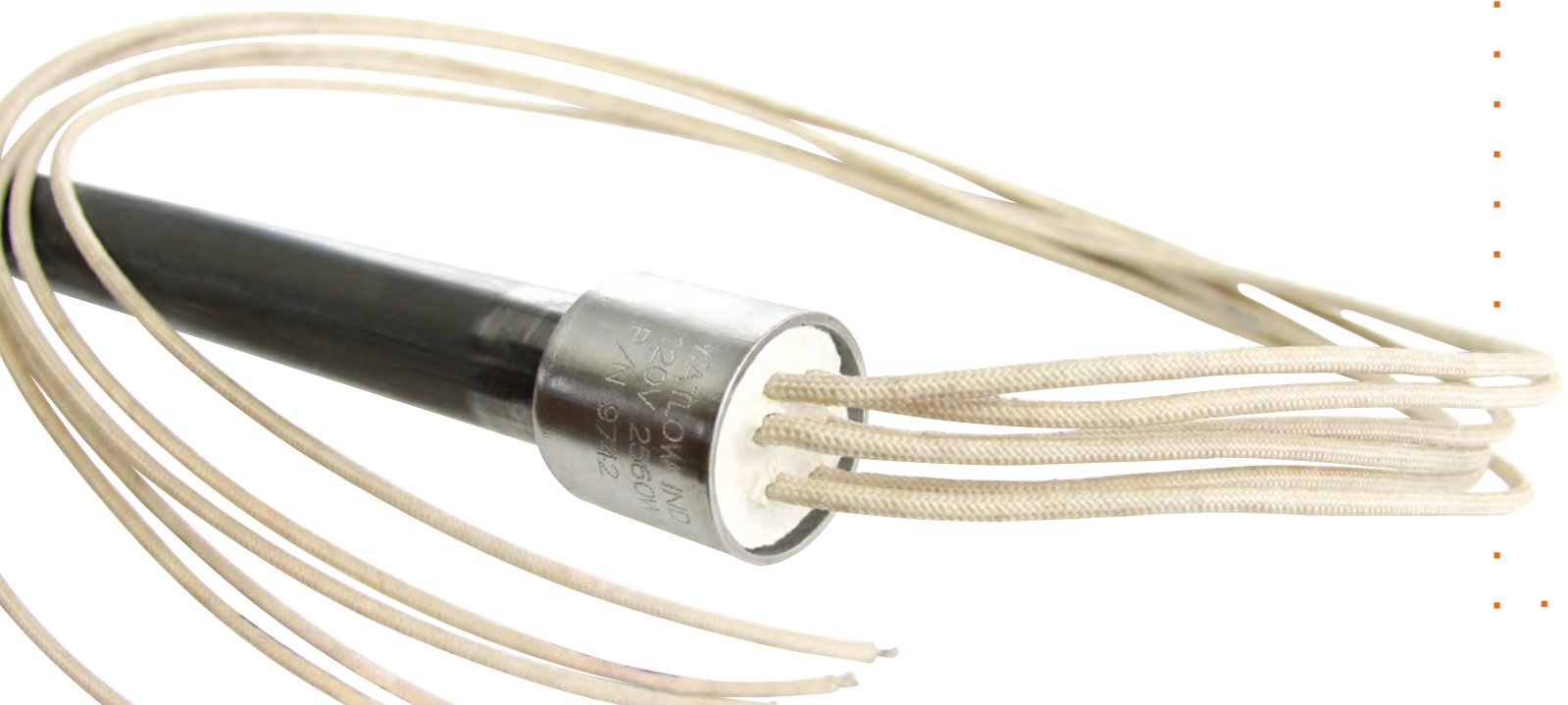

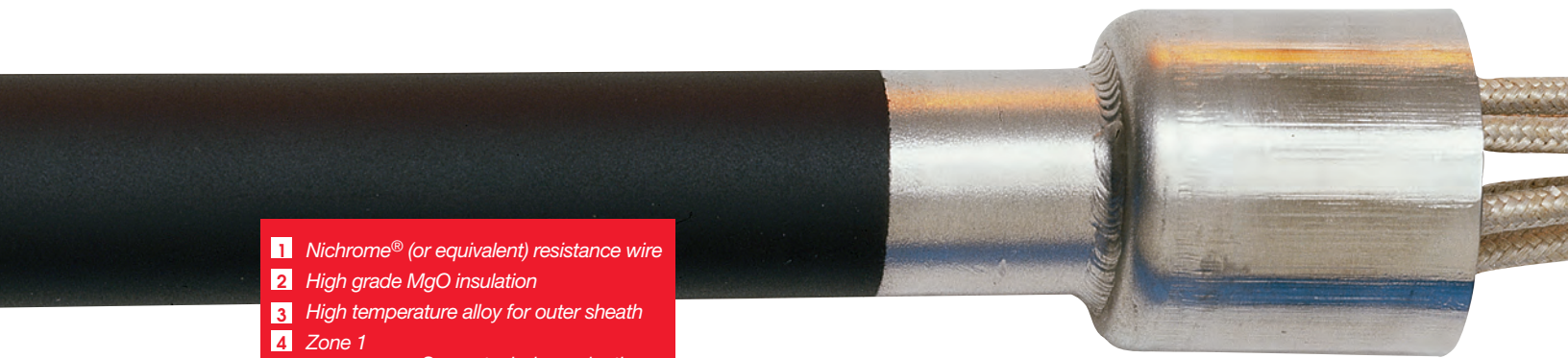

- 1** Nichrome® (or equivalent) resistance wire
 - 2** High grade MgO insulation
 - 3** High temperature alloy for outer sheath
 - 4** Zone 1
 - 5** Zone 2
 - 6** Zone 3
- Separate, independently
controllable heated zones

SHEATH TEMPERATURE AND WATT DENSITIES

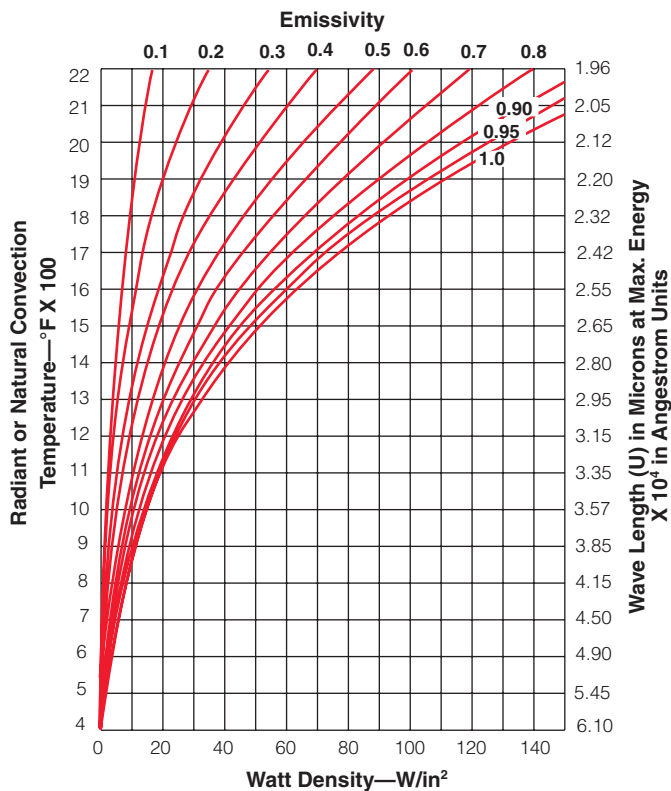

Determining MULTICELL Process Watt Density and Sheath Temperature: The process watt density is found on the W/in² scale (lower) at the intersection of the process temperature value (left temperature scale) and the 1.0 emissivity curve. The MULTICELL sheath temperature is found on the left temperature scale at the intersection of the heater emissivity curve (0.90) and the process watt density added to the heater design watt density (lower W/in² scale).

Note: These instructions are for new applications. For existing applications, use the 0.95 emissivity curve to determine sheath temperature, since well-oxidized MULTICELL heaters are more efficient.

TYPICAL LOOSE FIT SIZES

Standard MULTICELL Diameter	Platen Hole Size	Minimum Radius Bends
0.685 in.	³ / ₄ or ⁷ / ₈ in.	1.5 in.
0.935 in.	1, 1 ¹ / ₄ in. or larger	2.5 in.

Note: See Heater catalog for bending options.



CASE HISTORY FOR SOIL REMEDIATION

Application:

Watlow's MULTICELL heaters offer high temperatures, long heater life and easy installation for a soil remediation application.

Problem:

An industrial and waste treatment company needed to remediate soil contaminated by petrochemical applications. Several heating systems were tested, but most were unsuccessful.

The specifications called for a 40 foot (12 meter) heater to be fitted into a tube, which was then inserted into a well in the polluted soil. Ceramic heater rods were tried but were too brittle at 40 feet (12 meters) long. Gas heating solutions required additional costly security and were difficult to incorporate on the job site. A TPC heating system was also tried but when the current was applied directly to a metal tube there were problems with the power supply and insulation.

Solution:

Watlow analyzed the application and recommended its MULTICELL heater. It is a robust heater that is capable of high temperatures and is easy to install. The MULTICELLS were fitted into the tubes, which were put within wells in the polluted soil. MULTICELL's high temperature capabilities (up to 2050°F (1120°C)) increased the soil temperature and removed the volatile pollutants. There are several heaters running at once, and each heater is controlled individually and can be in operation for several months. Other benefits include:

- Reduced installation and service costs
- Manufactured to customer's exact specifications
- Supplied with both sensors and power controllers reducing the number of vendors

There continues to be good technical dialogue between Watlow and the customer, which has also helped make this application successful.

CASE HISTORY FOR CONVENTIONAL USE

Application:

Watlow's radiant MULTICELL heaters reduce costly downtime and provide long heater life for glass forming and tempering ovens.

Problem:

Plate glass needed to be heated to approximately 1300°F (704°C) to enable bending. The customer was using an oven equipped with open coils in ceramic plates. But during the bending process, some glass would typically break, fall into the open coils and cause them to fail. Over time, the glass breakage and coil damage prevented the furnace from achieving the correct process temperature. The furnace would need to be shut down and allowed to cool, before removing the broken coils and ceramic plates. The tedious maintenance process resulted in lost production time and could last as long as seven days.

Solution:

Durable and easy to remove and install MULTICELL heaters from Watlow replaced the coil and ceramic heaters, resulting in minimal downtime and nearly hassle-free maintenance and replacement. Additionally, an internal thermowell with a removable and easily replaced thermocouple was used to enhance and prolong heater life by improving control of the process.

The customer saw these immediate benefits:

- Dramatically reduced downtime
- Longer heater life
- Easy heater and thermocouple replacement for hassle-free maintenance

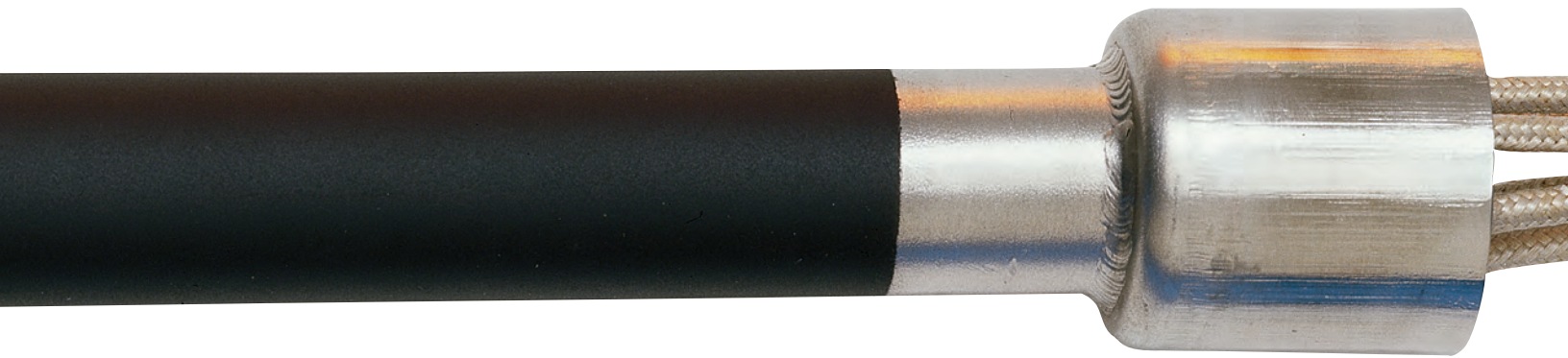

CASE HISTORY FOR MANUFACTURING POLYSILICON INGOTS

Application:

Watlow's MULTICELL heaters provide accurate and controlled heating in polycrystalline silicon CVD reactors.

Problem:

Temperature consistency and uniformity within the CVD reactor is critical in the manufacturing process of polysilicon ingots.

CVD reactors are large pressure chambers with bell-shaped enclosures and multiple silicon rods. As a result of high temperatures and controlled pressure, gasses in the chamber undergo chemical reactions and produce silicon growth on filaments or rods inside the reactor.

To prevent silicon deposition on the inner surfaces of the reactor and to maintain the structural integrity of the reactor, the shell must be cooled while the rods are kept at a precise temperature.

Solution:

To ensure optimum ingot production and the integrity of the equipment, the chamber must be preheated.

An internal preheater is used to increase the temperature of the polysilicon rods and reduce the voltage point when the rods begin to conduct a current.

Watlow's MULTICELL heater bundle was chosen because of its robust and accurate heating capability to deliver high temperatures in harsh environments. Reliable and efficient heating technology has a direct impact on reducing the cost per kilogram of the polysilicon produced. The MULTICELL is lowered into the reactor, in proximity to the filaments. The MULTICELL heats the environment to the optimal temperature and

is then removed from the reactor. The reactor is then sealed and the filaments are connected to desired voltage while the reaction gasses are introduced.

The MULTICELL heater bundle is the preferred heat source due to its straightness, rigidity, excellent high temperature and zoning capabilities.

Contact your Watlow representative today to find out how your problems can be solved.





Find out more about Watlow and how we can provide thermal solutions for your company:

Phone: 1-800-WATLOW2 (1-800-928-5692)

E-mail: inquiry@watlow.com

Website: www.watlow.com

Watlow Products and Technical Support Delivered Worldwide

North American Technical Support & Sales Offices

North America 1-800-WATLOW2
(1-800-928-5692)

Asian Technical Support & Sales Offices

Australia +61 3 9335 6449
China +86 21 3532 8532
India +91 40 6661 2700
Japan +81 3 3518 6630
Korea +82 2 2628 5770
Malaysia +60 3 8076 8745
Singapore +65 6773 9488
Taiwan +886 7 288 5168

European Technical Support & Sales Offices

France +33 (0) 1 41 32 79 70
Germany +49 (0) 72 53 / 94 00-0
Italy +39 024588841
Spain +34 91 675 12 92
United Kingdom +44 (0) 115 964 0777

Latin American Technical Support & Sales Office

Mexico +52 442 217 6235

About Watlow

Watlow designs and manufactures industrial heaters, temperature sensors, controllers and supporting software as well as assemblies – all of the components of a thermal system. The company partners with its customers to optimize thermal performance, decrease design time and improve efficiency of their products and applications.

Watlow brings its experience to numerous industries, including semiconductor processing, environmental chambers, energy processes, diesel emissions, medical and foodservice equipment.

Since 1922, Watlow has grown in product capability, market experience and global reach. The company holds more than 200 patents and employs 2,000 employees working in nine manufacturing facilities and three technology centers in the United States, Mexico, Europe and Asia. Watlow also has sales offices in 15 countries around the world. The company continues to grow, while the commitment remains the same – to provide its customers with superior products and services for their individual needs.

Your Authorized Watlow Distributor is:

Watlow® is a registered trademark of Watlow Electric Manufacturing Company.
MULTICELL™ is a trademark of Watlow Electric Manufacturing Company.
Nichrome® is a registered trademark of Driver-Harris Company.