

PMx[L,M][2,4]xx-[3,5]Axxxxx

- 1 analog input
- 2 DIO
- 1 limit loop
- 4 outputs (Digital or Process)
- CIP registers - red text

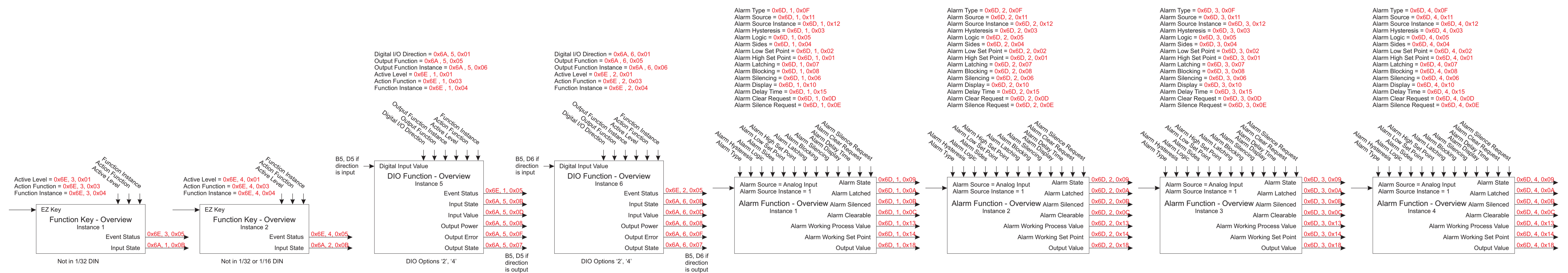
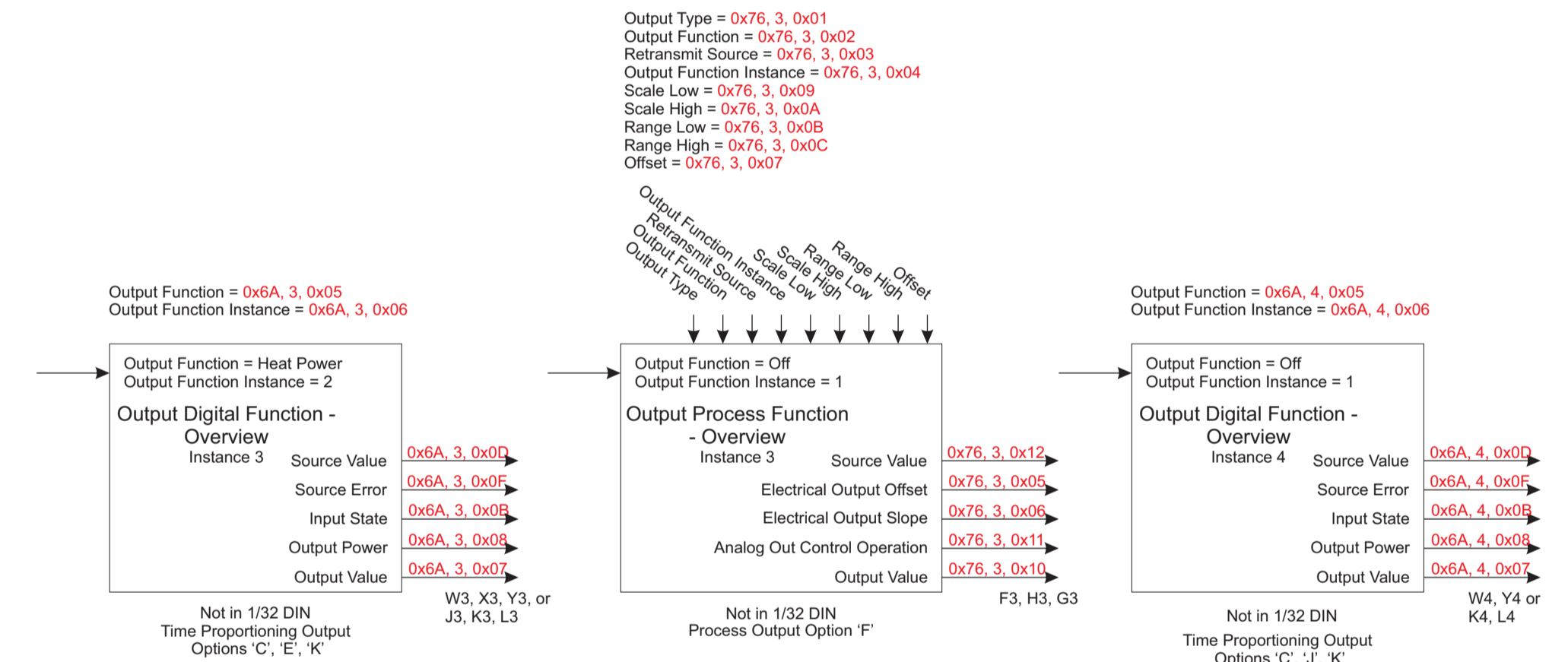
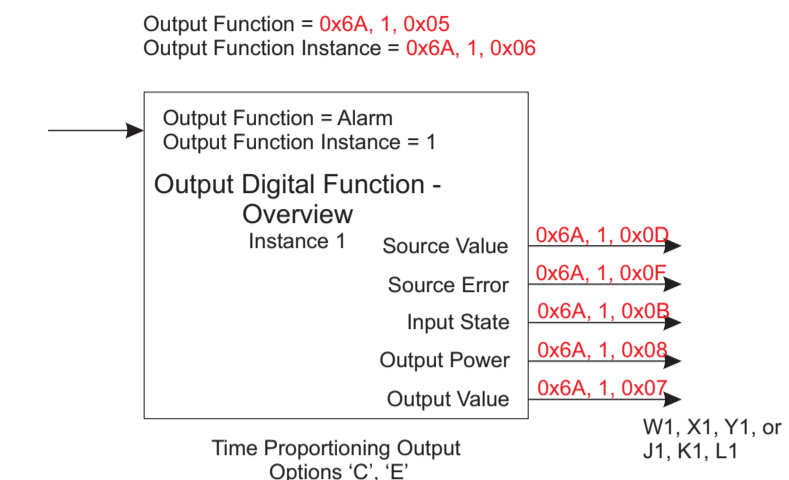
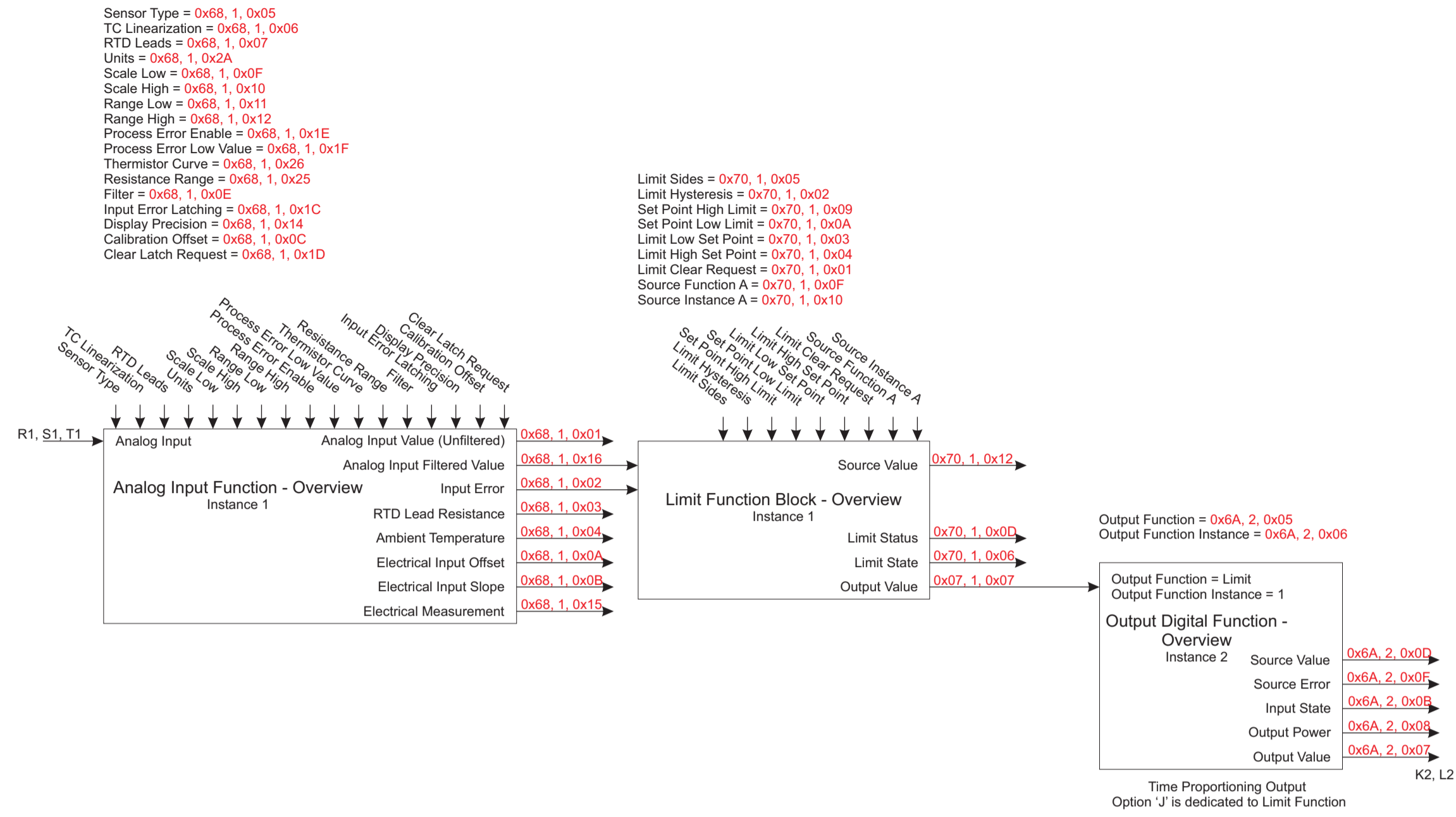

PMx[L,M][1,3]xx-[3,5]Axxxxx

- 1 analog input
- 0 DIO
- 1 limit loop
- 4 outputs (Digital or Process)
- CIP registers - red text

